



# *Installation instructions*



Adjustable strut bearings (Street): **54741**

Errors and changes excepted. Current installation instructions for the respective product can also be found at [www.burkhardt-engineering.com](http://www.burkhardt-engineering.com).

**Please note before installation:**

- The certificate must match the technical data of the vehicle (axle load, vehicle type, &).
- The product must comply with the certificates and these installation instructions (check marking on dome bearing (54741)).
- The scope of delivery must be checked for completeness:
  1. 2x strut bearing (left C right different)
  2. 1x fastening set (10 stud bolts, 10 spacers and 10 nuts)
  3. 6x M8\*20 bolt incl. spacers for bolting the strut brace
- The table below is intended as an indication of the vehicles for which the strut mounts are intended. However, this is not binding for the parts certificate, as identification is only legally permissible via the type approval number of the corresponding vehicle!

Manufacturer	Model	Designation	Adapter ring
BMW	M2 S55	F87	<b>10537-2 (15.5 mm)</b>
BMW	M3	F80	<b>10537-2 (15.5 mm)</b>
BMW	M4	F82, F83	<b>10537-2 (15.5 mm)</b>
<u>Not suitable for:</u> BMW M2 F87 nit N55 engine 272 kW			

- Should any difficulties arise during installation, our support team is available during normal opening hours. See footer for contact details!

**Note during installation:**

- The conversion may only be carried out by trained personnel using suitable tools.
- The following installation instructions and the associated parts certificate must be observed.
- Under no circumstances should the piston rod lock nut be moved with an impact wrench.
- The street bearing of the dome bearing for holding the piston rod must not be lubricated under any circumstances, as this can significantly reduce the service life of the bearing.

## The installation

1. The strut bearings must be prepared before installation by fitting the stud bolts as follows.

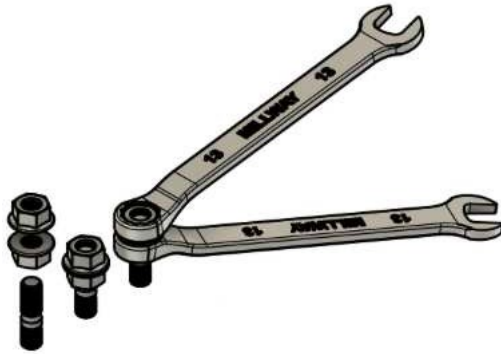

Screw two nuts on the longer threaded side of the stud bolt against each other so that they no longer twist. If the nuts still twist in the next step, apply a little more force.



The stud bolts can now be fitted from above with a tightening torque of 4 Nm at the previously determined positions, as shown in the adjacent illustration.

Then loosen the two nuts again and unscrew them from the stud bolt. Make sure that the stud bolt does not come loose from the support plate of the dome bearing!

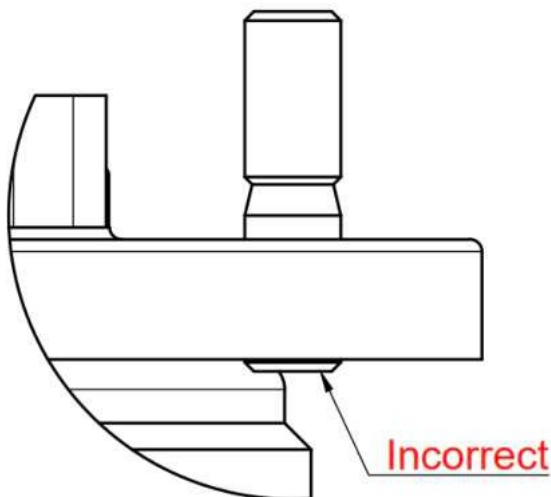

The stud bolt must not protrude from the underside of the carrier plate, as otherwise correct support of the deep groove ball bearing cannot be guaranteed.

2. Remove the suspension struts incl. support bearing of the front axle from the vehicle on both sides according to the manufacturer's instructions.

3. Secure the spring with a spring compressor and remove the existing support bearing from the damper.
4. Then carefully separate the deep groove ball bearings (to be reused) from the existing support bearings.
5. Unlike the standard support mounts, the adjustable strut mounts are not identical for both sides and must therefore be assigned to the correct side of the vehicle:

xxxxx -1 Left side  
xxxxx -2 Right side



**Compare Millway product number:**

- The strut bearing with marking 1 goes on the left-hand side (driver's side for left-hand drive vehicles)!
- The strut bearing with marking 2 goes on the right-hand side (passenger side on left-hand drive vehicles)!

6. The deep groove ball bearings can now be transferred to the adjustable strut bearings:

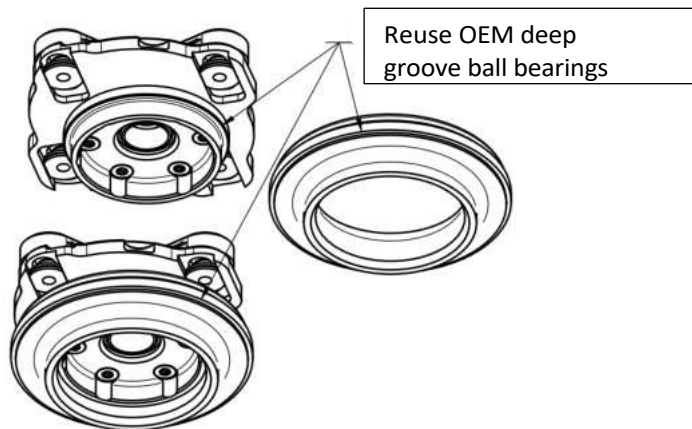

7. All components of the suspension strut (shock absorber, spring, dust cover, bump stop, spring pad, adapter sleeves (if present), adjustable strut bearings incl. deep groove ball bearing) and lock nut can now be refitted. The tightening torque of the original lock nut can be found in the vehicle manufacturer's specifications.

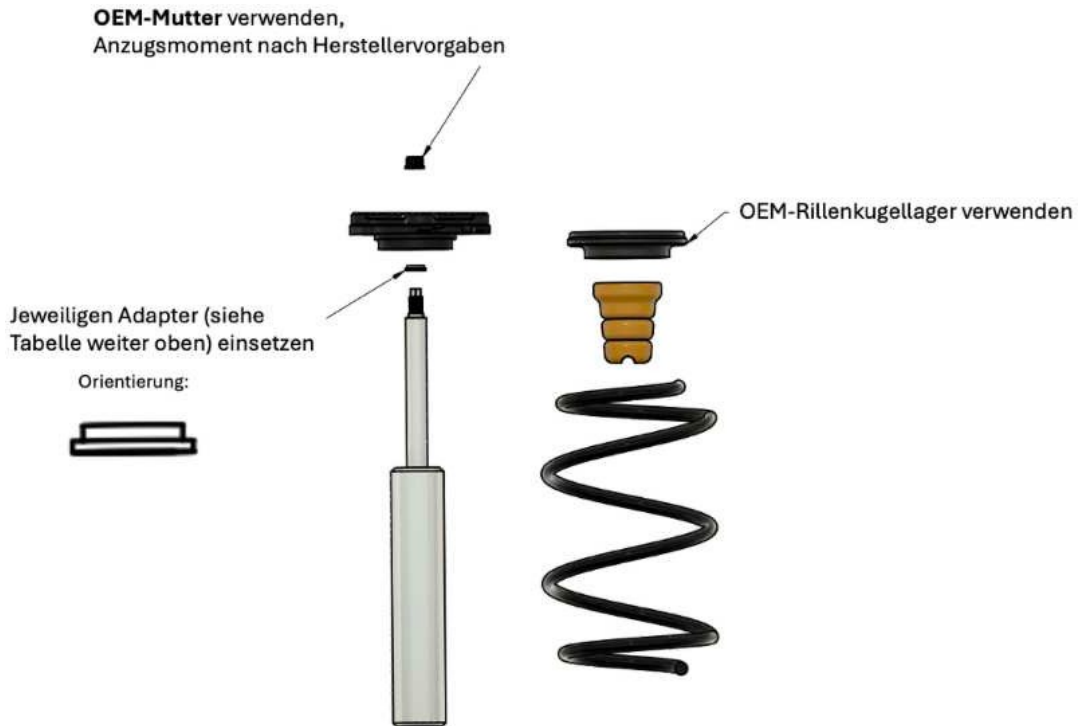

8. A camber setting of 0 mm should be selected initially, as it is easier to increase the camber during wheel alignment than to reduce it.



9. The spacers and nuts must now be fitted as shown in red in the adjacent illustration. The tightening torque for the nuts is 24 Nm.

10. If a wheel alignment is not carried out directly, the bolts marked in yellow must be tightened to a torque of 21 Nm.

11. To adjust the camber during wheel alignment, loosen the screws marked in yellow sufficiently to move the piston rod mount towards the center of the vehicle.

12. The strut brace is now attached using the enclosed screws and

**Note after installation:**

- The axle geometry must be measured after installing the strut mounts and adjusted if necessary, as a change in the camber can also affect other parameters.  
**Caution:** Camber values above 2° on the front axle are not permitted in road traffic
- Make sure that the strut bearing is moved with a suitable tool and without force so that it is not damaged during the camber adjustment. It may be necessary to take the weight off the front axle.
- All screw connections that had to be loosened to adjust the axle geometry must now be retightened to the tightening torque specified above.
- After installation, the vehicle must be presented to a technical service (such as TÜV, Dekra, etc.) with the enclosed parts certificate so that the correct installation can be approved.