



installation instructions



Domlager (Uniball): **55307**

Errors and changes excepted. Current installation instructions for the respective product are also at www.burkhart-engineering.com to find.

Please note before installation:

- The report must correspond to the technical data of the vehicle (axle load, vehicle type, ...).
- The product must comply with the reports and these installation instructions (Check marking on strut mount 55307).
- The scope of delivery must be checked for completeness:
 1. 2x strut mounts (left & right different)
 2. 2x adapter sleeves below
 3. if necessary 2x adapter sleeves above
- The table below is intended to provide an indication of the vehicles for which the Strut bearings are provided. However, this is not binding for the parts certificate, as identification is only legally permitted via the type approval number of the corresponding vehicle!

Manufacturer	Model	Designation
Porsche	718 Cayman GT4	982
Porsche	718 Boxter GT4	982
Porsche	GT2 inkl. RS	991
Porsche	GT3 incl. RS	991

- If you encounter any difficulties during installation, our support team is available during normal opening hours. Contact details can be found in the footer!

Please note during installation:

- The conversion may only be carried out by trained personnel using suitable tools be performed.
- The following assembly instructions and the associated parts certificate must be strictly observed.
- Under no circumstances should the piston rod lock nut be moved with an impact wrench.
- The uniball bearing of the strut bearing for holding the piston rod must not be lubricated under any circumstances, as this can drastically reduce the service life of the bearing.

The installation

1. Remove the front axle struts including the support bearings on both sides from the vehicle according to the manufacturer's specifications.
2. Secure the spring with a spring compressor and remove the existing support bearing from the damper tear down.
3. The deep groove ball bearings or plain bearings are reused, the existing
The strut bearing is replaced 1:1. Depending on the model and year of manufacture, it may be necessary to make small changes here. If a 1:1 replacement is not possible, our support team can be contacted for individual solutions.
4. In contrast to the standard support bearings, the adjustable strut mounts are not identical for both sides and must therefore be assigned to the correct side of the vehicle:

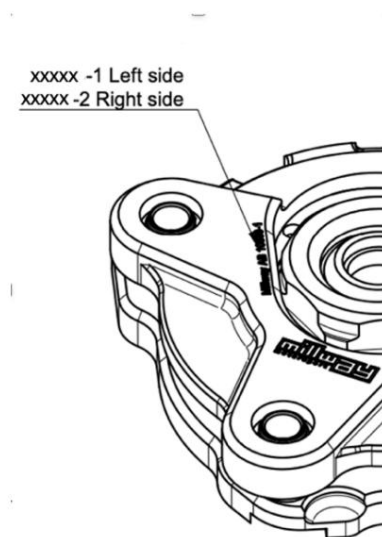

Compare Millway product number:

- Strut bearing with marking 1 goes on the left side (driver's side in left-hand drive vehicles)!
- Strut bearing marked 2 goes on the right side (passenger side in left-hand drive vehicles)!

5. The sleeves at the bottom and, if necessary, at the top are to be installed as shown in the following diagram.
assemble:



6. In the last step, the strut with strut bearing can be fitted, taking into account the tightening torque. If the vehicle in question allows a standard camber adjustment, this should initially be set to a minimum, since it is easier from a mechanical point of view to increase the camber during later wheel alignment than to reduce it again.

To do this, the strut mount must be moved outwards towards the fender using the long holes in the vehicle dome. See the following illustration:



Please note after installation:

- The axle geometry must be measured after the strut mounts have been installed and adjusted if necessary, since a change in camber can also affect other parameters.

Attention: Camber values of more than 2° on the front axle are not permitted in road traffic

- It is important to ensure that the strut mount is moved using suitable tools and without using force, so that it is not damaged during the camber adjustment. The front axle may need to be relieved of load.
- All screw connections that had to be loosened to adjust the axle geometry must now be retightened using the tightening torque specified above.
- After installation, the vehicle must be presented to a technical service (such as TÜV, Dekra, ...) with the enclosed parts certificate so that the correct installation can be confirmed.