



installation instructions



Adjustable strut bearings (uniball): **55703**

Errors and changes excepted. Current installation instructions for the respective product are also at www.burkhart-engineering.com to find.

Please note before installation:

- The report must correspond to the technical data of the vehicle (axle load, vehicle type, &).
- The product must comply with the reports and these installation instructions (Check marking on strut bearing 55703).
- The scope of delivery must be checked for completeness:
 1. 2x strut mounts (different left & right)
 2. 1x mounting set (6 studs, 6 spacers and 6 nuts)
 3. 2x adapter sleeves lower (lower)
 4. if necessary 2x adapter sleeves upper (upper)

- The table below is intended to provide an indication of the vehicles for which the Strut bearings are provided. However, this is not binding for the parts certificate, as identification is only legally permitted via the type approval number of the corresponding vehicle!

Manufacturer	Model	Designation	Notice
MINI		F56	For MINI vehicles with three or five Screwing points of a strut bearing on the vehicle dome and a Bolting point of the strut brace on the Domlager

- If you encounter any difficulties during installation, our support team is available during normal opening hours. Contact details can be found in the footer!

Please note during installation:

- The conversion may only be carried out by trained personnel using suitable tools
 - The following assembly instructions and the associated parts certificate must be strictly observed.
 - The locking nut of the piston rod must not be moved with an impact wrench under any circumstances.
 - The uniball bearing of the strut bearing for holding the piston rod must not be lubricated under any circumstances, as this can drastically reduce the service life of the bearing.

The installation

1. The strut mounts must be prepared before installation by tightening the studs as **be mounted as follows.**



Two nuts on the longer threaded side of the stud bolt screwed together so that they no longer
If the nuts
In the next step, twist it a little more and apply a little more force.



Now the studs can be a tightening torque of 4 Nm from above, as shown in the adjacent figure, at the previously determined positions.

Afterwards, the two
Loosen the nuts again and remove
It is important to ensure that the stud does not come out of the

the support plate of the strut bearing comes loose!

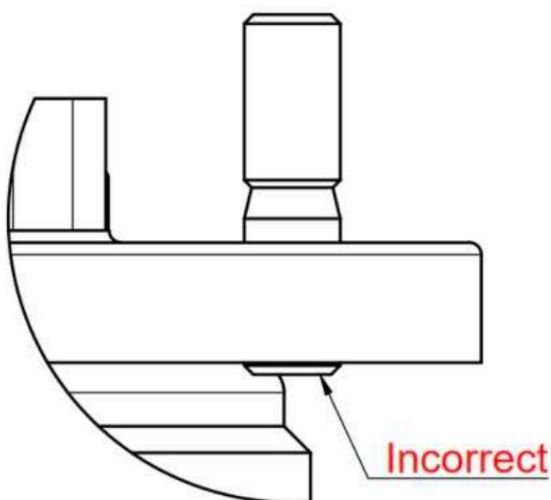

The stud bolt must not be on the protrude from the underside of the carrier plate, otherwise correct support of the deep groove ball bearing cannot be guaranteed.

2. Remove the suspension struts including the support bearings of the front axle on both sides from the vehicle according to the manufacturer's specifications.
3. Secure the spring with a spring compressor and remove the existing support bearing from the damper tear down.
4. Then carefully separate the deep groove ball bearings (to be reused) from the existing support bearings.
5. The adjustable strut mounts are not identical for both sides and must therefore be assigned to the correct side of the vehicle:

xxxxx -1 Left side
xxxxx -2 Right side



Compare Millway product number:

- Strut bearing with marking 1 goes on the left side (driver's side in left-hand drive vehicles)!
- Strut bearing marked 2 goes on the right side (passenger side in left-hand drive vehicles)!

6. Now the deep groove ball bearings can be transferred to the adjustable strut bearings become:

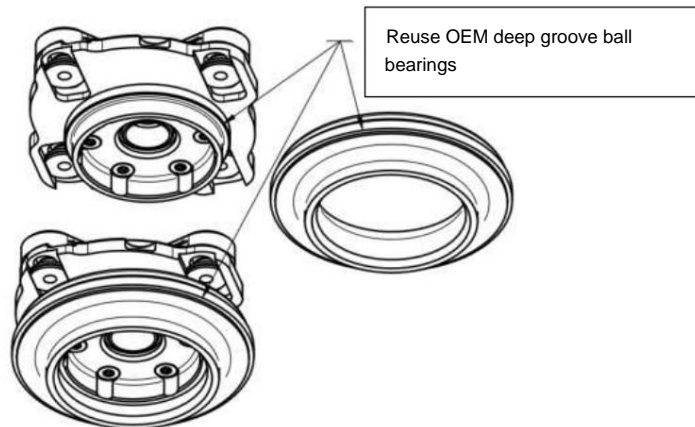

7. All components of the shock absorber can now be reassembled.
The adapter sleeves are installed according to the diagram below so that there is no play between the bearing and the piston rod.



The tightening torque of the original piston rod lock nut can be found in the vehicle manufacturer's specifications.

8. A camber setting of 0 mm should be selected initially, since it is easier to increase the camber during wheel alignment than to decrease it.



9. As marked in red in the adjacent figure, the spacers and nuts must now be mounted. The

The tightening torque of the nuts is 24 Nm.

10. If not directly a

If wheel alignment is carried out, the yellow marked screws must be tightened with a torque of 21 Nm.

11. To adjust the camber during wheel alignment, the yellow marked screws must be loosened sufficiently to allow the piston rod to move towards the center of the vehicle.

Please note after installation:

- The axle geometry must be measured after the strut mounts have been installed and adjusted if necessary, since a change in camber can also affect other parameters.

Attention: Camber values of more than 2° on the front axle are not permitted in road traffic

- It is important to ensure that the strut mount is moved using suitable tools and without using force, so that it is not damaged during the camber adjustment. The front axle may need to be relieved of load.

- All screw connections that had to be loosened to adjust the axle geometry must now be retightened using the tightening torque specified above. • After installation, the vehicle must be presented to a technical service (such as TÜV, Dekra, etc.) with the enclosed parts certificate so that the correct installation can be verified.